



# Tectite access doors

CC



## Description

The Tectite range of duct access doors is designed to provide easy and speedy access to smoke, fire and volume control dampers, coils, filters and other air conditioning and ventilating equipment mounted inside ductwork.

The range of five sizes have been carefully selected to provide different degrees of access from single handed to head and shoulder entry.

Tectite doors are of double skin 'sandwich' construction complete with 20mm thick high density insulation and are sealed to prevent any insulation migration.

The one-piece mounting frames are pressed for accuracy and pre-punched on inner and outer flanges.

This feature allows doors to be installed so that a flush finish is achieved on plain or insulated ductwork. All sizes of door are fitted, as standard, with a retaining chain between the door and frame.

Tectite access doors are suitable for high, medium and low pressure applications and meet the requirements of DW144 Specification classes A and B.

## Specification

**Frame**-Seamless one piece 0.7mm galvanised mild steel.

**Door**- Outer panel 0.7mm galvanised mild steel  
Inner panel 0.7mm galvanised mild steel.

**Insulation**- 20mm thick fire retardant insulation. Positive seal.

**Gasket**- Progressive action camlocks, zinc plated.

**Fasteners**- Retaining chain, zinc plated, between door and frame.

## Dimensions

Note: these additional camlocks on Model CC20 only.

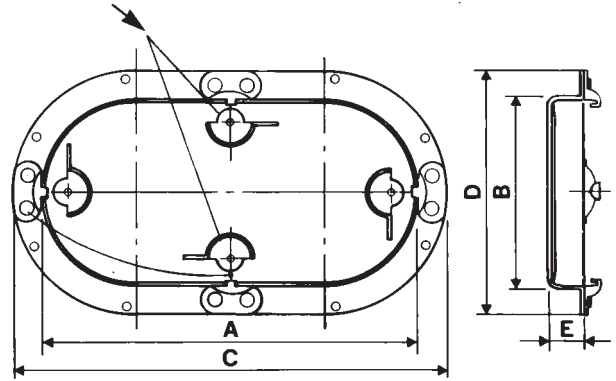

Model	CC00	CC10	CC20
Nom Size	200 x 125	300 x 150	460 x 250
A	203	298	462
B	127	157	258
C	241	349	502
D	165	197	298
E	30	30	30

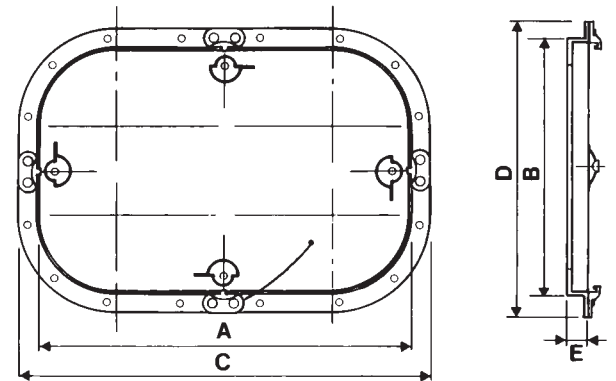

Model	CC30	CC40
Nom Size	530 x 360	635 x 430
A	538	640
B	355	433
C	578	679
D	400	476
E	30	30

We recommend that an additional gasket is fitted to all models to achieve a leakage rate to Class C.

Special frames to accommodate 50mm insulation and provide a flush finish are available.