



Data sheet
testo 420

Volume flow hood

testo 420 – light, precise and convenient



Less than 2.9 kg weight

Flow straightener for more precise measurement at swirl outlets

Removable and tiltable measuring instrument with a large display

App integration via Bluetooth for fast and easy monitoring and reporting on site

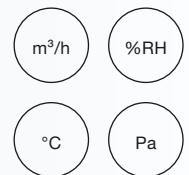

Bluetooth
+ App

testo Smart App
for free download



The testo 420 volume flow hood is the light, precise and convenient solution for regulating volume flow at larger air inlets and outlets. At swirl outlets in particular, the flow straightener significantly reduces the usual measurement errors. This allows users to fulfil hygienic Indoor Air Quality guidelines and stipulations in ventilation and air conditioning systems quickly and precisely, e.g. in industry, office rooms or in cleanrooms.

Handling is especially easy with a uniquely low weight of less than 2.9 kg and ergonomic handles. The measuring instrument can be tilted and removed for more comfortable readout of the measurement values. The app connection enables mobile devices to be used via Bluetooth as a secondary display, for customer and measurement data management and as a remote control. This makes using a tripod for high ceilings, for example, especially safe and comfortable. Moreover, the user can use the app to finalize and send the measurement report directly on site.



Technical data

testo 420 set

testo 420 volume flow hood, with measuring instrument, body, 610 x 610 mm flow hood, 5 x tension rods, USB cable, batteries and trolley, incl. calibration protocol



Part no. 0563 4200

testo 420

testo 420 differential pressure measuring instrument incl. batteries and calibration protocol



Part no. 0560 0420

General technical data

Compatibility	requires iOS 12.0 / Android 6.0 or newer requires mobile end device with Bluetooth® 4.0
Operating temperature	-5 to +50 °C
Storage temperature	-20 to +60 °C
Weight	2.9 kg
Standard hood	610 x 610 mm
Battery type	Alkali manganese, mignon, Type AA
Battery life	40 h (Zeroing interval 10 seconds, display illumination off, Bluetooth off)
Display	Dot matrix with illumination 3.5 inch
Memory	2 GB internal (approx. 18,000 measurements)
Interface	Micro USB
Material	Measuring instrument housing: ABS Base: PP Standard hood: Nylon
Data transmission	Bluetooth®, e.g. for connection to testo 400

Sensor types

	Volume flow	NTC	Capacitive humidity sensor	Differential pressure sensor	Absolute pressure probe
Measuring range	50 to 4000 m³/h	-20 to +60 °C	0 to 100 %RH	-120 to +120 Pa	+700 to +1100 hPa
Accuracy ±1 digit	±3 % of m.v. +12 m³/h at +22 °C, 1013 hPa (85 to 3500 m³/h)	±0.5 °C (0 to +60 °C) ±0.8 °C (-20 to 0 °C)	±1.8 %RH +3 % of m.v. at +25 °C (5 to 80 %RH)	±2 % of m.v. +0.5 Pa at +22 °C, 1013 hPa	±3 hPa
Resolution	1 m³/h	0.1 °C	0.1 %RH	0.001 Pa	0.1 hPa

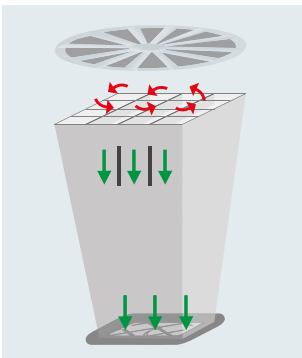

Functional principle of the flow straightener.



Flow straightener for significantly more precise measurements at swirl outlets.



App integration via Bluetooth for displaying the measurement data on mobile devices and finalizing the measurement report on site.



Stable, wheeled tripod with central fitting for secure working at high ceiling outlets.



Accessories

	Part no.
Flow hood 360 x 360 mm, with bag	0554 4200
Flow hood 305 x 1220 mm, with bag	0554 4201
Flow hood 610 x 1220 mm, with bag	0554 4202
Flow hood 915 x 915 mm, with bag	0554 4203
Tripod, extendable to 3.3 m, with rollers	0554 4209
Connection hose; silicone; length 5 m; max. load 700 hPa (mbar)	0554 0440
Connection hose silicone-free for differential pressure measurement, length 5 m, load up to maximum 700 hPa, (mbar)	0554 0453
testo Smart App	0501 5001

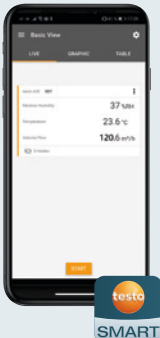

The testo Smart App

- For all kinds of IAQ applications of the testo 420 – from measurement to documentation
- Compatible with all Bluetooth-enabled Testo measuring instruments for air conditioning/refrigeration systems and heat pumps
- Integrated measurement database incl. customer and measuring point management
- Quick analysis thanks to clear presentation of the values, e.g. as a graph
- Create digital measurement reports including photos as PDF/CSV files on site and email them straight away





GET IT ON
Google Play



Download on the
App Store

Calibration Certificates

Part no.

ISO calibration certificate, 15 to 2000 m ³ /h bi-directional	0520 0154
ISO calibration certificate, 10 measurement points regularly distributed over the measuring range (bi-directional) Calibration points 150/300/450/600/750/900/1050/1200/1350/1500 Nm ³ /h	0520 0194
ISO calibration certificate, 5 measurement points regularly distributed over the measuring range (bi-directional) Calibration points 300/600/900/1200/1500 Nm ³ /h	0520 0164
DAkkS calibration certificate, 15 to 1800 Nm ³ /h bi-directional	0520 1264
DAkkS calibration certificate, 10 measurement points regularly distributed over the measuring range (bi-directional) Calibration points 150/300/450/600/750/900/1050/1200/1350/1500 Nm ³ /h	0520 0294
DAkkS calibration certificate, 5 measurement points regularly distributed over the measuring range (bi-directional) Calibration points 300/600/900/1200/1500 Nm ³ /h	0520 0264





Comfortable measurement thanks to low weight



Removable instrument allows Pitot tube measurements in ducts (Pitot tube available separately)

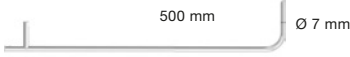
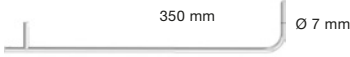
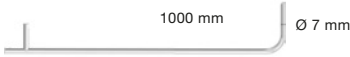

Pitot tubes / air flow velocity matrix

Probe type	Dimensions Probe shaft/probe shaft tip	Measuring range	Part no.
Pitot tube, 500 mm long, Ø 7 mm, stainless steel, for measuring flow velocity*	 500 mm Ø 7 mm	Measuring range: 1 to 100 m/s Operating temperature: 0 to +600 °C Pitot tube factor: 1.0	0635 2045
Pitot tube, 350 mm long, Ø 7 mm, stainless steel, for measuring flow velocity*	 350 mm Ø 7 mm	Measuring range: 1 to 100 m/s Operating temperature: 0 to +600 °C Pitot tube factor: 1.0	0635 2145
Pitot tube, 1000 mm long, stainless steel, for measuring flow velocity*	 1000 mm Ø 7 mm	Measuring range: 1 to 100 m/s Operating temperature: 0 to +600 °C Pitot tube factor: 1.0	0635 2345
Air flow velocity matrix, telescope with ball head, length 1.8 m, with 2 x 2 m connection hose, silicon-free, with Velcro attachment on the telescope, for connection to differential pressure measuring instrument			8721 0025

*Connection hose required (order no. 0554 0440) or (order no. 0554 0453)

1981 0414/msp/12.2022

Subject to change without notice.

Lindab Ltd

Lindab Ventilation Branches

Aberdeen	01224 708582	Exeter	01626 835032	Manchester	0161 876 0688
Basildon	01268 532016	Gateshead	0191 482 5995	Norwich	01603 747532
Belfast	02890 781607	Glasgow	0141 419 3800	Nottingham	0115 985 1923
Birmingham	0121 552 6100	High Wycombe	01494 463490	Sheffield	0114 244 5444
Bristol	0117 977 1345	Kent	01474 579800	Southampton	02380 262111
Cardiff	02920 794503	Leeds	0113 297 1111	Stoke-on-Trent	01782 383460
Croydon	0208 603 0850	Leicester	0116 255 6044		
Enfield	0208 805 3656	Lincoln	01522 567087		

Email: sales@lindab.co.uk
Web: lindab.co.uk
Eshop: lindab.co.uk/eshop

© 2020 Lindab Ltd. is a registered trademark of Lindab Ltd, as are the designation of our product ranges. Lindab Ltd reserves the right to make alterations without prior notice.

Whilst every care has been taken in the preparation of this brochure, some changes may have occurred since publication. Lindab Ltd is not responsible for omissions or typographical errors.

