



# Blast gate damper

BG



## Description

Zest blast gate dampers are designed primarily for use in industrial exhaust systems extracting fumes, dust, wood waste, etc. They have also been used extensively in agricultural machinery, marine ventilation, stokers, furnaces and grain drying plants.

Zest blast gates are easy to operate with the freely moving blade being locked into the open or closed position by means of a simple thumb screw.

## Dimensions

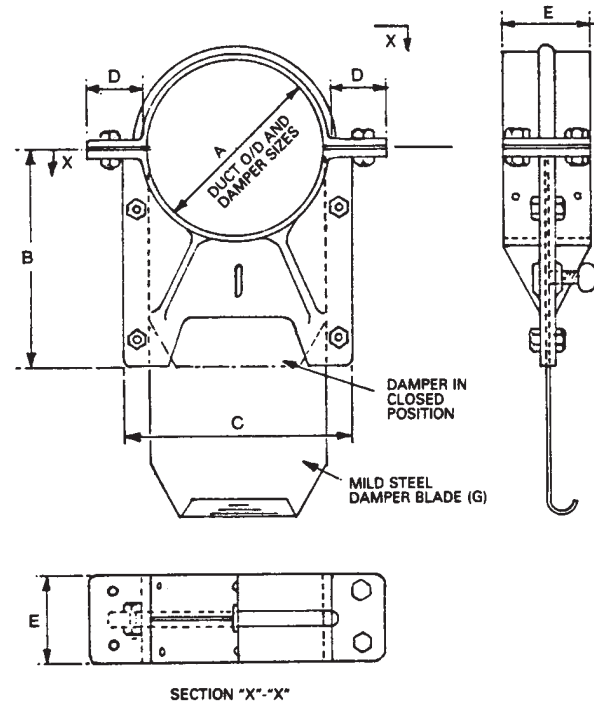

Damper Size	A	B	C	D	E	G Gauge
63mm	63mm	92mm	94mm	20mm	45mm	1.6
80mm	80mm	108mm	110mm	23mm	46mm	1.6
100mm	100mm	126mm	131mm	28mm	51mm	1.6
125mm	125mm	154mm	164mm	38mm	55mm	1.6
150mm	150mm	172mm	190mm	37mm	78mm	1.6
160mm	160mm	175mm	189mm	35mm	79mm	1.6
180mm	180mm	190mm	220mm	45mm	78mm	1.6
200mm	200mm	230mm	240mm	38mm	78mm	1.6
224mm	224mm	236mm	272mm	40mm	80mm	1.6
250mm	250mm	240mm	291mm	45mm	82mm	1.6
280mm	280mm	290mm	308mm	54mm	108mm	1.6
300mm	300mm	330mm	350mm	60mm	98mm	1.6
315mm	315mm	345mm	375mm	60mm	120mm	1.6
355mm	355mm	400mm	410mm	60mm	154mm	1.6